

GS221 ADDRESSABLE GAS DETECTOR



GS221 addressable gas detector is designed to detect gas leaks, to generate an alarm and to transmit this information to the control panel. GS221 addressable gas detector can work with all Redban control panels. It can detect all kinds of flammable and combustible gases. The device detects gases such as Natural gas (methane), bottled gas (propane), LPG (Liquefied petroleum gas), CNG (natural gas).

When a gas leakage is detected, analog data is transmitted to the control panel over a communication line. Thanks to the relay output on it, it can be operated independent of the panel with only 24V supply. When GS221 detects while operating independent of the panel, the relay output active on it. In this way, a desired device (such as a gas valve) can be controlled. GS221 Gas detector is addressed by RB1201 Address programmer and this address information is stored in its permanent memory.

Features

- Robust and aesthetic PC/ABS case
- Microprocessor based design
- Light path indicator
- Test button
- NO / NC Relay output
- Programmable with RB1201 address programmer
- Address and data stored in nonvolatile memory
- Ability to work standalone
- EN 50194-1 standard



EN 50194-1:2009 + EN 60335-1:2020
EN 50270:2015 + EN 61000-6-3:2021
CoC No: 353

TECHNICAL SPECIFICATIONS

LOOP OPERATING VOLTAGE	16 - 30 Vdc
LOOP OPERATING CURRENT	<150µA @ 24 VDC (every 8 seconds with LED blink enabled)
MAXIMUM ALARM CURRENT	<7 mA @ 24 VDC (LED on)

ENVIRONMENTAL SPECIFICATIONS

HUMIDITY	10% - 93% Relative Humidity, Non-condensing
OPERATING TEMPERATURE	-10°C - 50°C
SENSOR LIFE	5 Years
COVERAGE AREA	max. 50 m ³

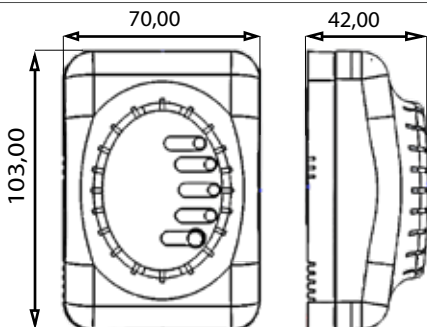

PHYSICAL SPECIFICATIONS

CASE MATERIAL	PC/ABS Case
DIMENSIONS (H x W x D)	103 x 70 x 42 mm
WEIGHT	150 grams