

# SA880-IS ADDRESSABLE FIRE ALARM SIREN WITH BUILT-IN ISOLATOR



SA880-IS Addressable Indoor Siren is designed for audio/visual warning in addressable system. SA880-IS is ideal for providing warnings in fire and security applications of buildings such as hotels and residences during emergency situations. It emits a loud warning to ensure the evacuation of building occupants. SA880-IS series sirens can be connected by the loop in the addressable fire alarm system. In addition, in case of a short circuit in the loop line, it isolates the next part of the loop line using the internal isolator. Upon activation, the SA880-IS initiates an auditory alert and also provides a visual alert with a red indicator and a white flash. These indicators have a 360° field of view. The device can be reset by de-energizing the power supply.

## Features

- Robust and aesthetic PC/ABS case
- Transparent red color
- visual warning led and flash
- 86 dB sound intensity at 1 meter (max. 105dB)
- Loop powered
- Programmable with RB1201 address programmer
- Programmable address information in nonvolatile memory
- EN54-3 & EN54-17 Certified



EN54-3:2001 + EN54-17:2005  
**CPR No: 1922-CPR-2167**

## TECHNICAL SPECIFICATIONS

LOOP OPERATING VOLTAGE	16 - 30 Vdc
LOOP OPERATING CURRENT	<150µA @ 24 VDC (every 8 seconds with LED blink enabled)
MAXIMUM ALARM CURRENT	<12 mA @ 24 VDC (LED on)
SOUND INTENSITY	86 dB nom. (max. 105 dB)

## ISOLATOR SPECIFICATIONS

ISOLATOR TYPE/SWITCH CURRENT	SSCS (A.3) / 230-400mA
ISOLATOR RECONNECT/LEAKAGE CURRENT	3-13mA / max. 18mA
STANDBY CURRENT/SERIAL RESISTANCE	max. 150uA / max. 1 ohm

## ENVIRONMENTAL SPECIFICATIONS

HUMIDITY	10% - 93% Relative Humidity, Non-condensing
OPERATING TEMPERATURE	-10°C - 50°C

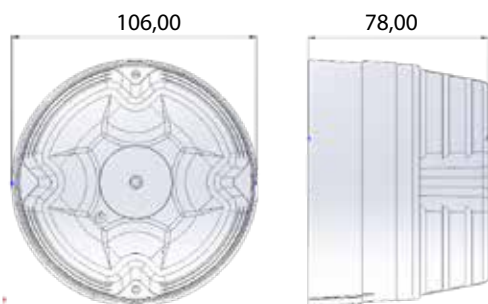

## PHYSICAL SPECIFICATIONS

CASE MATERIAL	PC/ABS Case
DIMENSIONS (H x D)	78 x 106 mm
WEIGHT	140 grams